

Vacuum Heat Treatment Advanced Solutions



AICHELIN Vacuum Furnaces



CONTENT

■ Heat Treatment All Over the World	2
■ Benefits of Vacuum Furnaces	3
■ Vacuum Hardening Furnaces	4
■ Vacuum Gas Quench Furnaces	6
■ Vacuum Brazing Furnaces	7
■ Vacuum Oil Quench Furnaces	8
■ All-In-One Vacuum Furnaces	9
■ Vacuum Tempering Furnaces	10
■ Low Pressure Carburizing Furnaces	12
■ Hydrogen Gas Quenching	13
■ Special Vacuum Furnaces	13
■ Control System	14
■ Vacuum Furnace Maintenance	15
■ Our Service	16

We Contribute to Heat Treatment All Over the World

The AICHELIN Group, with its 1,000 employees, is one of the world's leading providers of heat treatment solutions. These include industrial furnaces, industrial heating systems, control and automation systems, Industry 4.0 solutions and services. The company's roots go back to 1868 and provides leading enterprises in the industries of fastening technology, automotive, drive, transmission technology, aerospace, tooling, bearing and semi-finished products, hardening, steel and forging technology, mechanical and plant engineering and other sectors such as medical technology with state-of-the-art standard or customized heat treatment equipment and technologies.

AICHELIN is represented by subsidiaries in Austria, Germany, Slovenia, France and Türkiye. Its global presence includes subsidiaries and branches in China, India and the USA, as well as a sales network in further 22 countries.



Benefits of AICHELIN Vacuum Furnaces

EXTENDED LIFETIME AND RELIABILITY

Achieve an extended lifespan with consistent, reproducible results, ensuring reliable performance over time.

USER-FRIENDLY DESIGN

Benefit from easy operation and maintenance, enhancing user experience and reducing downtime.

ENERGY EFFICIENCY

Maximize energy efficiency with advanced insulation and a cold wall design that minimizes surface losses.

RAPID HEATING AND COOLING

Rapidly heat and cool both small and heavy charges, reducing cycle times, improving process efficiency and throughput.

PRECISE PROCESS CONTROL

Perform accurate process cycles using both furnace and load thermocouples for precise temperature control.

LOW MAINTENANCE COSTS

Utilize the optimized furnace design based on years of experience to ensure low maintenance costs combined with efficient performance.

FULL COMPLIANCE

Compliant with applicable international standards such as CQI-9, NADCA, NADCAP, AMS 2750 etc.

Vacuum Hardening Furnaces



STANDARD FURNACE DIMENSIONS

Type	Useful Dimensions (mm)	Useful Volume (dm ³)	Charge Weight (kg)	Heating Power (kW)
VF-1D-A-464	400 x 600 x 400	96	200	72
VF-1D-A-696	600 x 900 x 600	324	1000	140
VF-1D-A-9129	900 x 1200 x 900	972	1500	230
VF-1D-A-9159	900 x 1500 x 900	1215	1750	240

Special dimensions are available for your special needs.



Vacuum hardening furnaces are used in industrial sectors such as aviation, aerospace, energy, tooling, die and mold, automotive, medical industries and heat treatment companies.

AICHELIN offers solutions for vacuum heat treatment in full compliance with international standards such as AMS 2750, ASTM, NADCAP, NADCA CQI-9 etc.

Options include:

1. Different materials for heating chambers including graphite, molybdenum and tungsten
2. Wide vacuum range up to 10^{-2} mbar and higher
3. Process temperatures between 200°C to 2200°C
4. Cooling gas pressure up to 20 bar

Product Overview - Vacuum Furnaces

- Graphite insulated high pressure gas quenching vacuum furnaces for vertical and horizontal loading
- All-metal insulated high pressure gas quenching vacuum furnaces for vertical and horizontal loading

Vacuum Gas Quench Furnaces

- High efficiency molybdenum-graphite heating elements
- 200 – 1430°C process temperature range suitable for a variety of heat treatment applications
- Gas quenching up to 20 bar for your special heat treatment
- Nitrogen-argon-helium cooling option specific to your infrastructure and process
- Partial Pressure Control feature to prevent evaporation from the material surface in 10^{-2} mbar – 10^{-6} mbar
- Special cooling process to minimize distortion of parts
- Energy and time savings due to an optimized design

Heating of Furnace

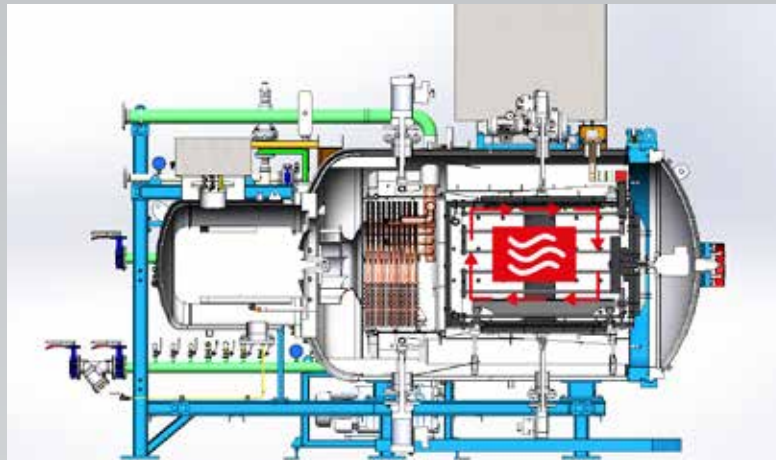

Cooling of Furnace

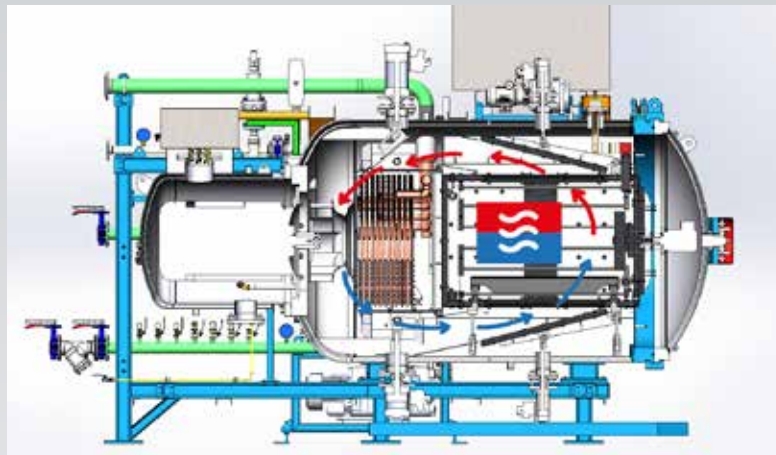

Vacuum Brazing Furnaces

Brazing is a special joining process that can be performed smoothly at high temperatures under vacuum. Vacuum brazing is in many ways advantageous compared to conventional brazing:

- Less distortion due to uniform heating and quenching
- Precise connections without surface oxidation
- Possibility of conducting tempering and hardening along with brazing in one furnace
- Possibility of effectively joining pieces with complex geometry



AICHELIN vacuum furnaces cover a wide range of brazing techniques from heat exchanger applications to complex aerospace parts with different brazing alloys and base materials. AICHELIN also offers designs with multiple heating zones including special insulation and heating systems for different processes such as aluminum brazing.

**High-Temperature
Vacuum Brazing
Furnaces with
All-Metal Heating
and Insulation**



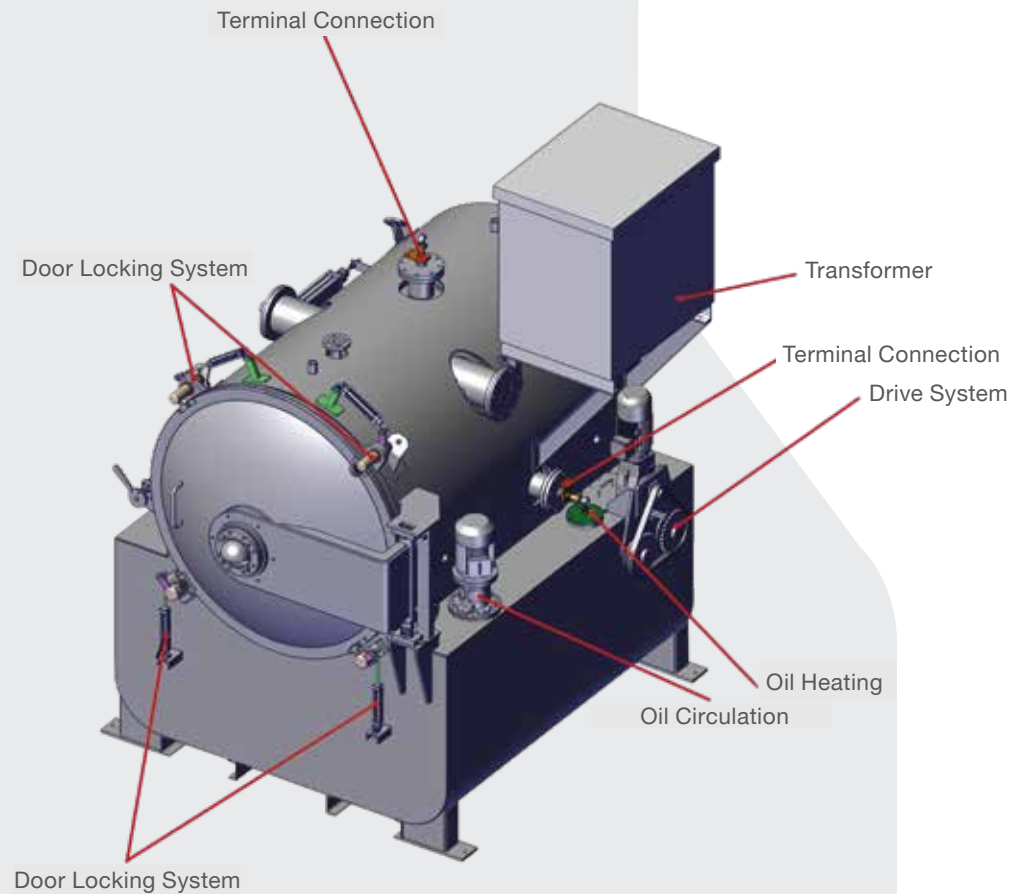

Vacuum Oil Quench Furnaces

VOQ series offers excellent hardening results for vacuum heat treatment processes where gas quenching cooling rates are not sufficient.

It also provides repeatable and recorded heat treatment results for your special products. Thanks to the **VOQ** sealed double-chamber design and special transfer mechanism, the whole process is completed under vacuum to ensure the highest quality.

VOQ CAN OPTIONALLY PROCESS THE FOLLOWING HEAT TREATMENT OPERATIONS:

- Carbonitriding with oil quenching
- Tempering

All-In-One Vacuum Furnaces



The All-In-One vacuum heat treatment furnace allows you to meet your various heat treatment requirements with one single furnace. It is an ideal investment for your business if you need to change between different heat treatment processes requiring oil or gas quench. Thus saving cost and space within your heat treatment department.



All-In-One Vacuum Furnace - cross section

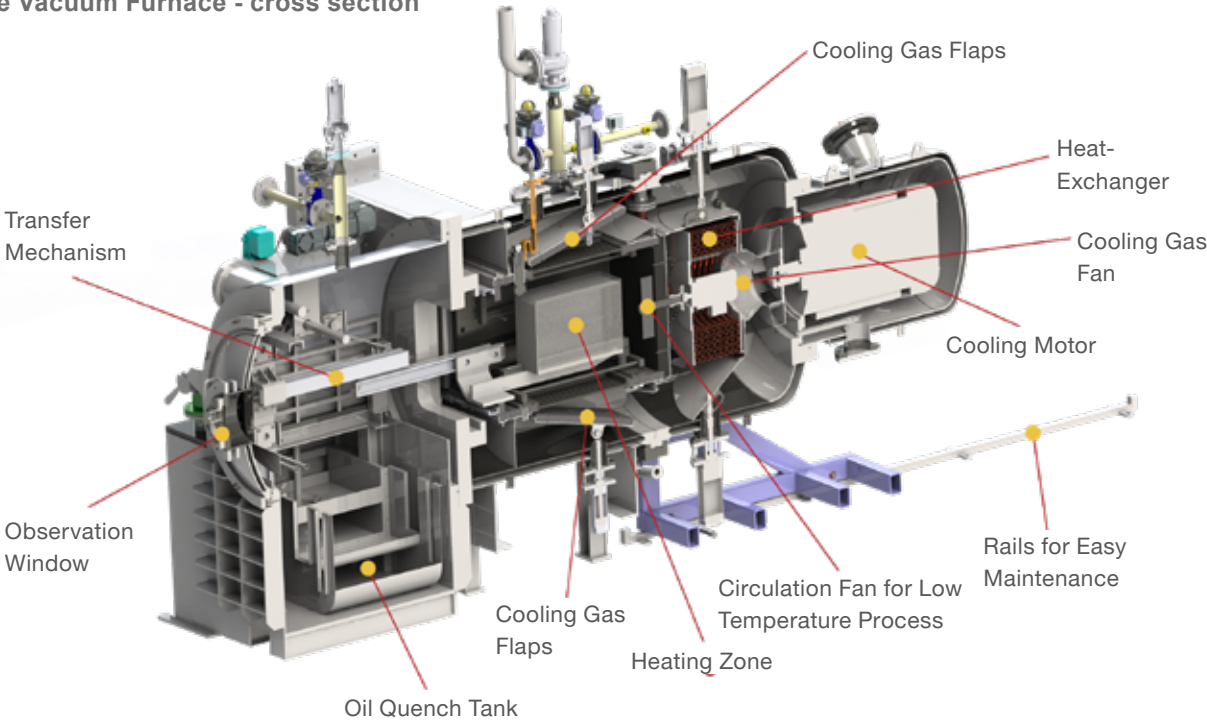

Vacuum Tempering Furnaces

AICHELIN direct heated vacuum tempering furnaces deliver excellent temperature uniformity, rapid heating and cooling performance in a single-chamber design. In order to achieve a clean surface of quenched parts after tempering the furnace is designed to ensure the necessary parameters for the desired surface quality. Deeper vacuum levels allow more flexibility for various heat treatment applications like aging of aircraft engine parts. AICHELIN vacuum tempering furnaces can process a wide range of materials and different processes like ageing, annealing or stress relieving.

VF-TE-DC SERIES VACUUM TEMPERING FURNACES

STANDARD FURNACE DIMENSIONS

Model Number	Useful Dimensions (mm)	Charge Weight (kg)	Heating Power (kW)
VF-TE-DC-696	600 x 900 x 600	1000	140
VF-TE-DC-9129	900 x 1200 x 900	1500	220
VF-TE-DC-101510	1000 x 1500 x 1000	2000	260

COOLING CYCLE

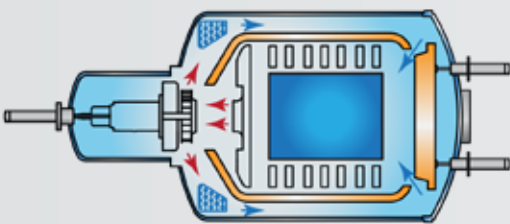

Excellent Temperature Uniformity



Up to 10^{-2} mbar Vacuum Level



Shorter Cycle Times



New Generation Cold Wall Technology

HEATING CYCLE

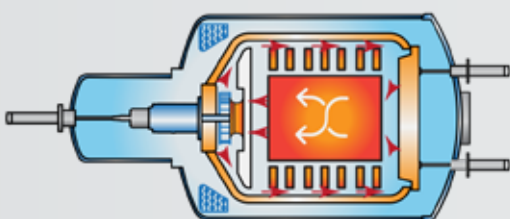

Clean Surface



Lower Energy Consumption



High Production Efficiency With Low Maintenance Needs

HEATING CHAMBER

The heating chamber is insulated with high density ceramic fiber installed between stainless steel shielding plates, stainless steel load support and cooling flaps.

HEATING ELEMENTS

Wide band Inconel heating elements ensure superior heat distribution to all sections of the load.

COOLING SYSTEM & CIRCULATION FAN

Our advanced cooling system consists of a special cooling fan with a water-cooled-motor and our high-capacity internal heat exchanger fully made from copper tubes with the best heat transfer capability and two cooling gas flaps actuated by pneumatic cylinders. After evacuation the furnace is pressurized with inert gas, the fan circulates inert atmosphere (N₂ and optional N₂+H₂, Ar, He) around the charge during both the heating and cooling cycles. The combination of radiant and convective heat transfer to the work pieces provides outstanding uniformity.

Furthermore, due to direct heating and direct cooling, the overall process time is reduced and efficiency is increased in comparison with conventional furnaces.



Low Pressure Carburizing Furnaces

LPC furnaces are a unique solution for surface hardening of steels, offering flexibility for both low and high production volumes. The following types of LPC furnaces can be supplied:

- Single Chamber High Pressure Gas Quench
- Double Chamber High Pressure Gas Quench
- Triple Chamber High Pressure Gas Quench with pre-heating
- Oil Quench Furnace
- Oil Quench Furnaces with pre-heating chamber
- Modular system with various heating and cooling chambers (oil and/or gas quench)

BENEFITS OF AICHELIN LPC FURNACES:

- Reduced process time due to optimized carbon transfer and temperature control
- Achievement of homogeneous case depth and hardness with low distortion after quench for carburizing of parts with complex geometry.



Hydrogen Gas Quenching

Gas quenching is an environmentally friendly, low-distortion technique. Hydrogen is one of the most effective gases for this application with rapid cooling rates and can be offered by AICHELIN as a further option with a safe design to use this light gas at up to 20 bar cooling pressure.

Special Vacuum Furnaces

TYPES OF SPECIAL VACUUM FURNACES

- High-Temperature Vacuum Furnaces
- Metal Injection Molding Furnaces (MIM)
- Custom Design Vacuum Furnaces
- Vacuum Nitriding Furnaces



Control System

Our advanced control system allows you to archive measured process parameters and access detailed records in the database anytime. Additionally, the system facilitates documentation of these parameters in line with system requirements, ensuring consistent quality. It also provides comprehensive information for visualizing and ensuring the technological process.

MAIN CHARACTERISTICS:

- Functionality and Easy Service Availability
- Integrated Management
- Easy and User-Friendly Interface
- Full SCADA Integration possible
- Remote Access to the SCADA System
- Compliance with NADCAP Standards
- System Accuracy Test (SAT) Integration
- Thermo-Elements Operation Time Trackers and Calibration Page
- Temperature Uniformity Survey (TUS) and Reporting

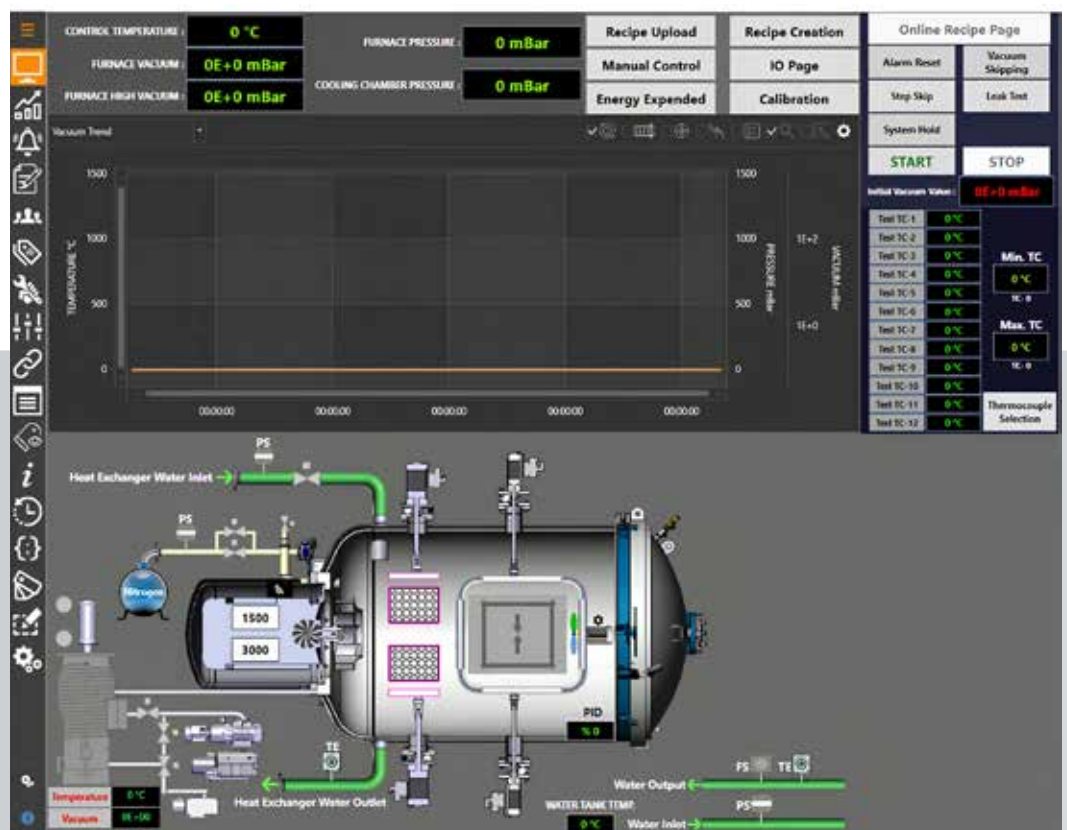

Vacuum Furnace Maintenance

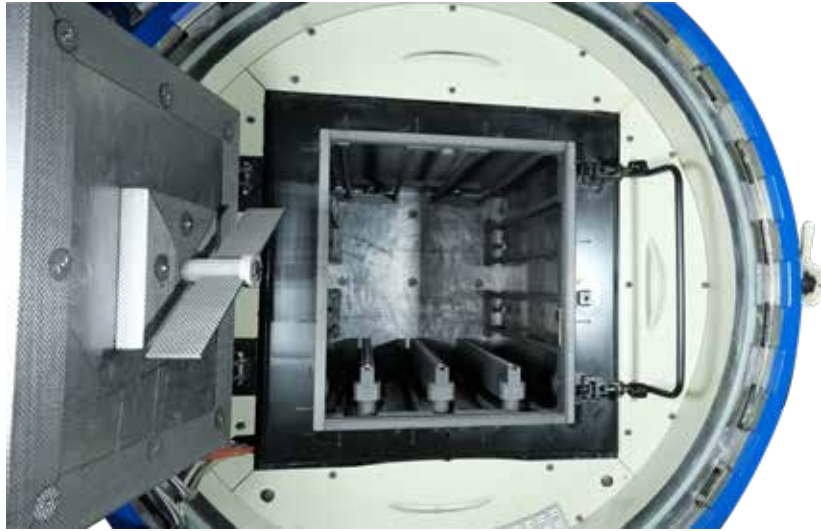

EASY AND QUICK MAINTENANCE

AICHELIN compact design provides easy and quick circulation fan repair and maintenance inside the heating chamber.

The CFC circulation fan and a special water-cooled motor are positioned on the heating chamber door for easy access, control and maintenance without the risk of damage to the heating chamber and having to remove the complete hot zone.

Our Service

AICHELIN vacuum furnaces not only meet the highest quality standards, but also optimum performance and reliability. At AICHELIN, we combine technical expertise, flexibility and highest quality with a first-class global service.

AFTER SALES & SPARE PARTS

- Annual Maintenance
- Spare Part Delivery
- Furnace Modernization
- TUS Test
- SAT Test
- Vacuum Leakage Test

AICHELIN can meet your spare parts requirements quickly and reliably in accordance with EN, DIN and ISO 9001 standards. In addition to supplying the highest quality heat treatment equipment, we also care about the continuity of your production programs.

After Sales Service and Spare Parts
service-vacuum@aichelin.com



Aichelin

vacuum furnaces

Technical changes reserved.
AICHELIN® is a registered trademark.
AVF_EN_2408

AICHELIN ST Vacuum GmbH
Fabriksgasse 3
A-2340 Mödling
Tel.: +43 2236 23 64 60
info-vacuum@aichelin.com

AICHELIN ST Vakum Fırınları A.Ş.
TOSB - Otomotiv Yan Sanayi
İhtisas OSB 1. Cad. 15 Yol
No:1 120 Çayırova
Kocaeli / Türkiye
Tel.: +90 262 658 29 14
info-vacuum@aichelin.com

www.aichelin.com